

**LIVEVIEW
GPS
COMMENTS**

RTV-5 INSTALLATION GUIDE



Thank You For Your Purchase! We Strive For Complete Customer Satisfaction, & Superior Customer Service. Please Do Not Hesitate To Contact Us.

TOLL FREE: 1-888-544-0494

FAX: 1-800-557-4314

DIRECT: 1-661-294-6805

THE RTV-5 INSTALLATION

Installation of your LiveViewGPS - RTV5 vehicle tracking device is as easy as it gets - just follow these three easy steps:

Plug The Two Antenna Cables & Wiring Harness Into The Transceiver:



Place the antenna (with the embossed letters "GPS" facing UP) on your dash at the base of the windshield.

Optimal Antenna Placement

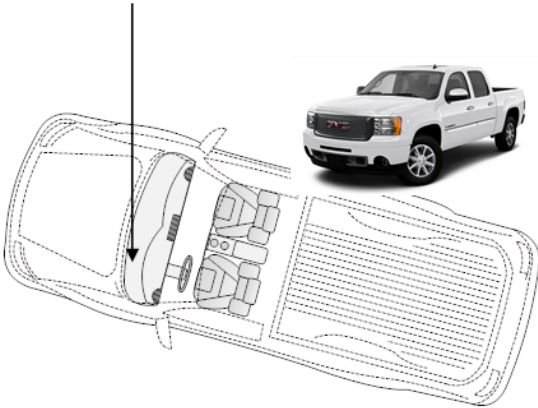

Run the cables along the side of the dash at the door hinge, and place the transceiver box under your dash. For best results, consider using a zip-tie to secure the transceiver to ensure it doesn't fall from beneath the dash.

Securely Attach The Wiring Harness To The RTV5 Transceiver. Connect the Following Wires:

- ◆ **RED** – 12 VDC Constant
- ◆ **BROWN** – Ignition/Accessory
- ◆ **BLACK** - Ground

Note: We Strongly Recommend Getting Your Power Directly Off The Ignition Column – Most Vehicles Have Constant Power & An Ignition #1 Wire There.

Note: Never Connect The Brown & Red Wire Together & Attach To A Constant Power Source! The Brown Wire Must Be Attached To An Ignition/Accessory Wire.

RTV-5: COVERT INSTALLATION

Many clients prefer to have the RTV-5 installed where the antenna & transceiver are hidden from view.

Note: GPS signal will penetrate glass, plastic, foam, fiberglass and wood. **GPS signal will NOT penetrate metal**, for this reason it is important to place the antenna with no metal or wiring between it and the sky.

The antenna of the RTV5 can be placed under the dashboard of most vehicle's and trucks (some high end imports, like Mercedes Benz have a metal foil under the dash – in which case an under dash mount will not work.

RTV-5: ACTIVATION

Visit www.LiveViewGPS.com And Choose The "Activate" Link At The Top Right Of The Site.

Select The "RTV-5" Link And E-Sign Your Activation Form. This process takes about 3 minutes.

Activations are done from 7 am - 4 pm PST. Once your activation order has been processed we will email you your username/password and URL for login. The entire process can take between 1 - 3 hours.

All activations are billed on a pro-rated term for the current month of service. We will auto-bill you on the first of every month.

If you wish to cancel, please submit your request to us no later than the 25th day of the month you wish to discontinue service. A service cancellation form is available at www.LiveViewGPS.com - top right of site "Cancel".

PROPER ANTENNA PLACEMENT

While installation of our vehicle tracking system is a simple three step process, the fact remains that proper antenna placement is crucial to uninterrupted operation.

A good installation location for the antenna should typically have visibility to 14 satellites at peak. If the antenna is installed in a location which only has visibility to a maximum of 9 satellites at peak, problems may occur which will result in intermittent operation.

An installation with a maximum view of only nine satellites, may operate wonderfully most of the time, but on those occasions when six satellites drop from view due to weather or other circumstances, it would leave the antenna seeing only three satellites – not enough to triangulate with any accuracy. Our system does not transmit location data when less than four satellites are in view – because we know the location would not be accurate.

So remember, metal causes problems for GPS antennae. As a result, placement of the antenna in a position which might be slightly obscured by metal – including wires, wiper blades, window tint or aluminum foil – may compromise antenna visibility of the GPS satellite constellation.

Proper Antenna Placement - Base Of Windshield, No Metallic Obstructions (Windshield Wipers, Wires, Etc.)



Base Of Windshield, With Antenna Either Exposed/Hidden



ANTENNA PLACEMENT AREAS

Above & Forward Of Instrument Cluster Hidden Under Dash

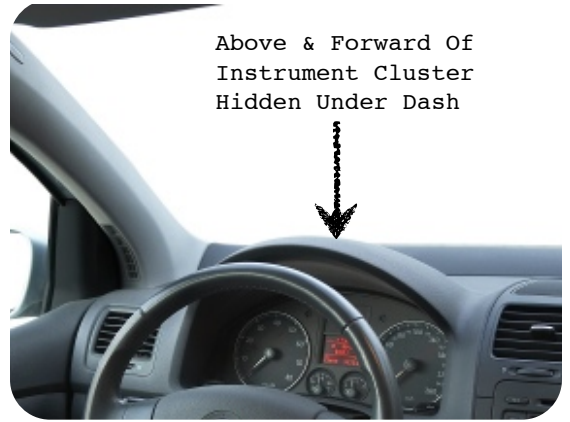

Hidden Inside "A" Pillar

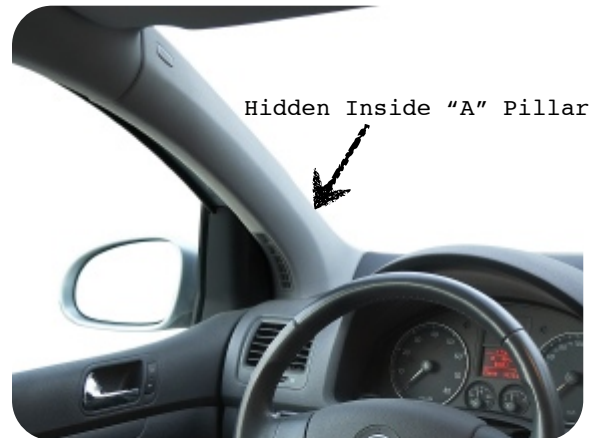

WARNING: Do Not Install Here If Antenna Will Obstruct, Block Or Interfere With Airbag Deployment

Under Fiberglass



WIRING SCHEMATIC

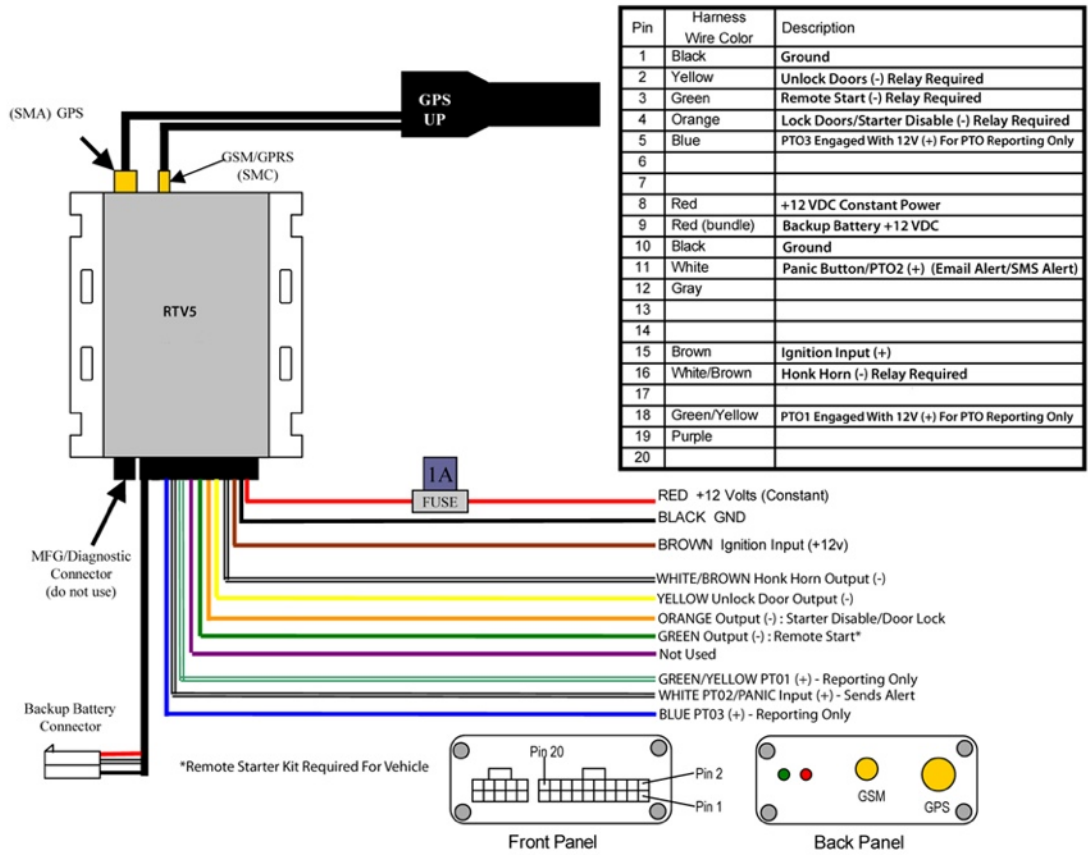

Diagnostic Codes:

THE RED LED will blink on the front of the device if a problem is encountered. Below are the codes describing each of these error conditions:

- | | |
|--|---|
| 1 Blink - Not Detecting Sim Card | 5 Blinks - Not Detecting SIM & GPS Not Tracking |
| 2 Blinks - No Cellular Signal - Check Antenna | 6 Blinks - Modem Not responding, firmware config |
| 3 Blinks - Not Tracking Satellites - Check Antenna | 7 Blinks - Modem & GPS not responding |
| 4 Blinks - No Cellular Signal/No GPS | 8 Blinks - GPS is OK, modem not registered on network |
| | 9 Blinks - Vehicle or antenna may need repositioning |

STARTER DISABLE - RELAY WIRING SCHEMATIC

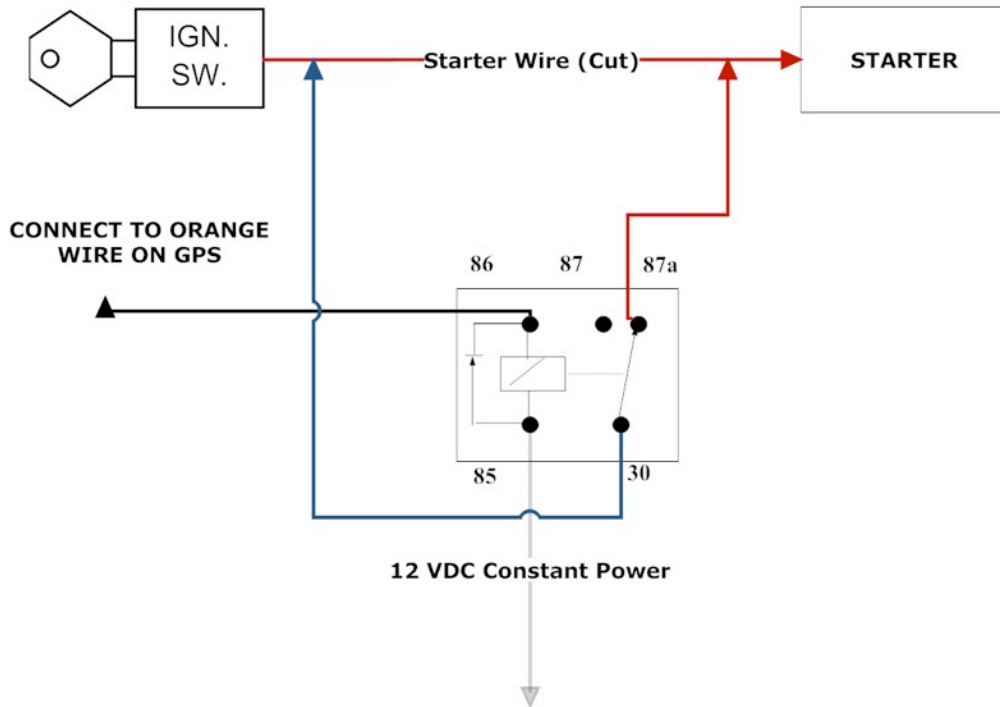

DOOR UNLOCK - RELAY WIRING SCHEMATIC

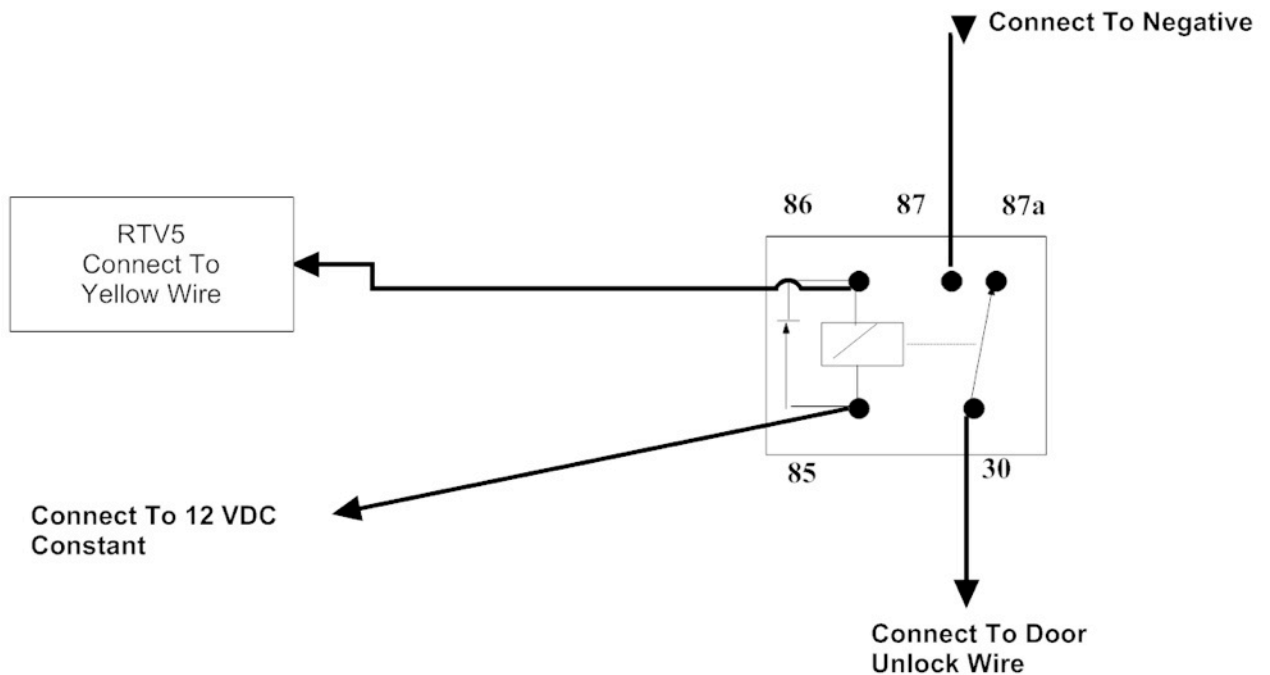

ACCESSORY WIRING SCHEMATIC

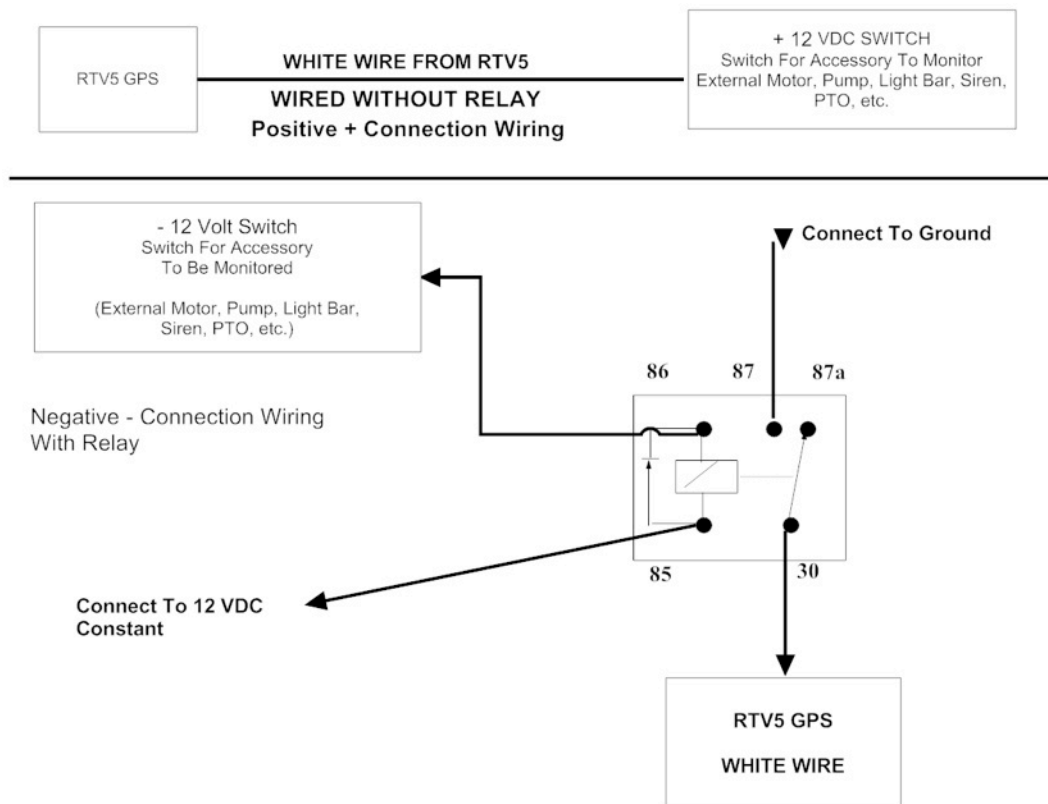

INSTALLATION BEST PRACTICES

Power for the RTV5 should be taken directly off of the ignition column.

There you will find constant power and ignition. This is the cleanest source of power for the device.

As much as possible, keep all RTV5 system wires away from speakers and speaker wires, as well as high powered electrical components.

Do Not use the radio as a source of power for any of the power leads to the RTV5, interference may result.

We recommend soldering all connections.

Secure RTV5 with zip-ties or other strapping - so it will not move around.

RTV5 - DEVICE SPECIFICATIONS

PHYSICAL SPECIFICATIONS

Dimensions	4 x 3.5 x 1.1 inches 102 x 89 x 25 mm
Weight	8 ounces 227 grams
GPS antenna conn.	SMA
Cellular antenna conn.	SMC
Power connector	20-pin 3mm Molex

ELECTRICAL SPECIFICATIONS

Operating Voltage	8 to 30V DC
Power Consumption	
Operating	<100mA @ 12V DC
Standby	13mA @ 12V DC
Sleep	<1mA @ 12V DC

ENVIRONMENTAL SPECIFICATIONS

Operating	-4° to 140°F (-20°C to 60°C)
Functional	-4° to 158°F (-20°C to 70°C)
Storage	-40° to 185°F (-40°C to 85°C)
Humidity	5 to 95% non-condensing
Shock and Vibration	SAE J1455
EMC/EMI	SAE J1113

GPS TECHNOLOGY

GPS	12 channel (with WAAS/SBAS)
Sensitivity	-160dBm tracking
Navigation	-160dBm (NMEA GPS output)
Horizontal accuracy	2.5m, 2.0m SBAS (CEP 50%)
Time-to-first-fix	38s (@ -130dBm)

OPTIONAL EXTERNAL MOUNT

ANTENNA

Exterior-mounted antenna, designed to be mounted in a non-ground plane environment. Mounting is a direct feed 3/4" threaded through-hole mount accommodating up to .06" of roof curvature available in black.

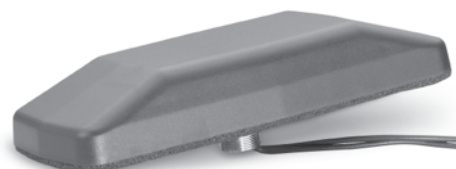

Dimensions: 7.6" L X 3.3" W X
Cable Length: 16'1"



Please Contact Sales For More Information.

PROFESSIONAL INSTALLATION

On-site professional installation is available nationwide.

Please contact us if you would like to arrange for installation.

TECHNICAL SUPPORT

Please contact us toll free 1-888-544-0494 or direct at 1-661-294-6805, Monday Through Friday From 7 am - 5 pm PST.

Support is also available on Saturdays from 7 am - 4 pm CST.

You can also email: info@liveviewgps.com for any support questions.



TROUBLESHOOTING GUIDE

By nature, any antenna placement will deteriorate signal reception even if only slightly.

If installed too far below the dash, the device may still function in areas where strong wireless data coverage is available. Despite the fact that it functions, such poor antennae placement may deteriorate signal quality from 5 bars to only 2 bars (hypothetical). In such an installation where the installation deteriorates signal quality by 3 bars, when your vehicle moves into an area where wireless data coverage only provides 4 bars of service, your device would have only 1 bar of service. Similarly, in an area where wireless coverage provides only 3 bars of service, your device would be unable to communicate due to signal deterioration based on poor antennae placement.

It is for this reason that a quality install and good antennae placement is critical.

Our objective is to install the antennae in a place where signal deterioration is kept to an absolute minimum.

COMMON PROBLEMS

1. The map shows my vehicle to be stopped, but the vehicle is moving.

Answer: This is caused by either of two potential issues :

A) The device is not transmitting

- 1) poor (or no) wireless data coverage
- 2) poor antennae location resulting in deteriorated wireless data signal
- 3) antennae not plugged into device

B) The GPS unit cannot see the sky (If lat=0 and lon=0, the unit will not transmit)

- 1) antennae facing downward (the embossed or printed text should face the sky)
- 2) poor antenna placement (GPS antennae cannot see sky through metal)
- 3) antenna is placed too far below the dash to have a good view of the sky.
- 4) On a new install, it may take several minutes for the GPS to establish location.

NOTE: The unit transmits more frequently when the vehicle is moving.

- 1) the device transmits every 30 minutes if the vehicle is stationary.
- 2) the device transmits every 5 (or 10) seconds if the vehicle is moving.
2. The system shows my vehicle to be hundreds of yards from its actual location.

Answer: The GPS unit does not have a good view of the sky.

- a) Under normal circumstances (with a good view of the sky) our devices are accurate to within 10-12 inches. There are 26 satellites in the GPS constellation. The more satellites the device can see, the more accurate the location.
- b) when vehicles are parked facing tall buildings (or in indoor garages or under metal awnings) large portions of the sky are often obscured.
- c) antenna placement is critical to ensure reliable and accurate operation.

3. When the device came on this morning, it showed the location from (another time).

Answer: The brown wire is not correctly connected to the accessory 12v (ignition) power source. When the device shuts down, it stores its last known location in a buffer. If the brown wire is not connected, the device cannot perform a graceful shutdown and thus cannot store its last known location properly.

4. I log in, and all I get is a map of the US. My vehicle doesn't show.

Answer: In almost every case, this is because it's a newly installed device and the unit hasn't yet transmitted its first packet of data (and thus cannot appear on the map because we don't yet know its location). It generally takes approximately 5 minutes after a new device has been powered up to begin transmitting.

This process can be hastened by driving the vehicle. Under normal circumstances, the device transmits every 5-10 seconds (depending on your wireless plan) when the vehicle is moving, but only once every 15-30 minutes if the vehicle is stationary. For this reason, it could take up to 30 minutes to make its first transmission if the vehicle remains stationary.

LEGAL NOTICE

© 2005-2010 LiveViewGPS, Inc.
All Rights Reserved.

This product or document is protected by copyright and distributed under the terms of a license agreement, restricting its use, copying, distribution and decompilation ("License Agreement"). No part of this document may be distributed without written consent from LiveViewGPS, Inc.

The product described in this document may be protected by one or more U.S. patents, foreign patents, or pending applications.

U.S. Patent Number 5,963,956 and 6,647,269. U.S. Patents Pending.

RESTRICTED RIGHTS/SPECIAL LICENSE RIGHTS

The documentation is provided with **RESTRICTED RIGHTS**. Use, duplication, or disclosure by the Government is subject to restrictions as set forth in the License Agreement and in subparagraphs (c)(1)(ii) of the Rights in Technical Data and Computer Software clause at DFARS 252.227-7013 or subparagraphs (c)(1) and (2) of the Commercial Computer Software—Restricted Rights at 48 CFR 52.227-19, or their equivalent, as applicable.

WARRANTY COVERAGE

LiveViewGPS, Inc. (LVGPSI)'s warranty obligations for this RTV5 series tracking unit are limited to the terms set forth below:

LVGPSI warrants the LVGPSI RTV5 series tracking unit against defects in materials and workmanship for a period of one (1) year from the date of original purchase ("Warranty Period").

Specifically, the date the equipment is shipped to the customer.

If a defect arises and a valid claim is received by LVGPSI within the Warranty Period, at its option, LVGPSI will (1) repair the product at no charge, using new or refurbished replacement parts, (2) exchange the product with a product that is new or which has been manufactured from new or serviceable used parts and is at least functionally equivalent to the original product, or (3) refund the purchase price of the product.

LVGPSI warrants replacement products or parts provided under this warranty against defects in materials and workmanship from the date of the replacement or repair for ninety (90) days OR for the remaining portion of the original product's warranty, whichever provides longer coverage for you. When a product or part is exchanged, any replacement item becomes your property and the replaced item becomes LVGPSI's property. When a refund is given, your product becomes LVGPSI's property.

This Limited Warranty does not apply to any non-LVGPSI hardware product or any software. LVGPSI is not liable for any damage to or loss of any programs, data, or other information stored on any media contained within the vehicle tracking or navigation systems.

This warranty does not apply: (a) to damage caused by accident, abuse, misuse, misapplication, or non-LVGPSI products; (b) to damage caused by electrical connection not conforming to instructions; (c) to a product or a part that has been modified without the written permission of LVGPSI; (d) if any LVGPSI serial number has been removed or defaced; (e) in the event of interruption or discontinuation of GPS satellite signal; or (f) in the event of interruption or discontinuation of the wireless coverage.

To the maximum extent permitted by law, this warranty and the remedies set forth above are exclusive and in lieu of all other warranties, remedies and conditions, whether oral or written, express or implied. LVGPSI specifically disclaims any and all implied warranties, including, without limitation, warranties of merchantability and fitness for a particular purpose. If LVGPSI cannot lawfully disclaim or exclude implied warranties under applicable law, then to the extent possible any claims under such implied warranties shall expire on expiration of the warranty period. No LVGPSI reseller, agent, or employee is authorized to make any modification, extension, or addition to this warranty.

SPECIFIC LIMITATION OF LIABILITY

To the maximum extent permitted by law, LVGPSI assumes no liability for direct, special, incidental or consequential damages of any kind under any circumstance resulting from the use of or inability to use LVGPSI products. Use of LVGPSI products constitutes your agreement to and acceptance of this limitation of LVGPSI liability.

As a knowledgeable and informed person, the user specifically acknowledges LVGPSI is not responsible for direct, special, incidental or consequential damages resulting from any breach of warranty or condition, or under any other legal theory, including any costs of recovering or reproducing any program or data stored in or used with the LVGPSI product, and any failure to maintain restricted airtime usage or failure to maintain the confidentiality of data stored on the product. LVGPSI specifically does not represent that it will be able to repair any product under this warranty or make a product exchange without risk to or loss of programs or data.

OBTAINING WARRANTY SERVICE

Please email info@liveviewgps.com with your LVGPSI model and serial number, and describe the anomaly in detail. LVGPSI will respond to your email with proper user diagnosis and repair or provide you with an authorization number and instruction for shipment for authorized repair. Use care and original shipping container to prevent shipping damage. No repair work will be done and your tracking unit will not be returned if an authorization number is not obtained in advance.