

# RTV-20

## Installation Guide



**LIVEVIEWGPS**

[www.LiveViewGPS.com](http://www.LiveViewGPS.com)

# Live Trac RTV-20



## TABLE OF CONTENTS

- What's in the Box.....1
- Activation.....2
- Antenna Connection & Placement.....3
- Installation.....5
- Wiring Schematics.....6
- Garmin Nuvi.....8
- Device Specs.....9
- Tech Support.....9
- Troubleshooting.....10
- Legal Notice.....11

# What's In The Box



[A] TRANSCIVER



[B] NUVI PATCH CABLE/ WIRING HARNESS



[C] ANTENNA

## Optional Equipment

(Not Included)



GARMIN NUVI INTEGRATION  
WORKS WITH THE FOLLOWING  
MODELS ONLY:

**GARMIN 255, 265, 465**

# Activation

*Activate your account prior to installing your tracking device.*



*When activating refer to the Serial # on label affixed to tracking device.*

Visit [www.LiveViewGPS.com](http://www.LiveViewGPS.com) and choose the "Activate" link at the top right of the site.

Select The "RTV-20" link and E-Sign your activation form. This process takes about 3 minutes.

Activations are done from 7 am - 4 pm PST. Once your activation order has been processed we will email you your username/password and URL for login. The entire process can take between 1 - 3 hours.

All activations are billed on a pro-rated term for the current month of service. We will auto-bill you on the first of every month.

If you wish to cancel, please submit your request to us no later than the 25th day of the month you wish to discontinue service. A service cancellation form is available at [www.LiveViewGPS.com](http://www.LiveViewGPS.com) - top right of site "Cancel".

# Antenna

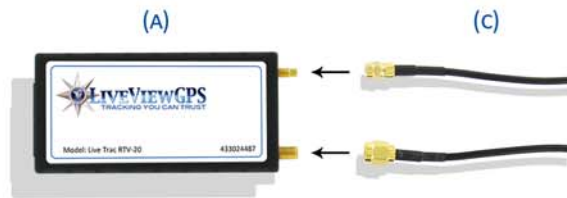

## ANTENNA CONNECTION

Plug the two (C) Antenna Cables into the (A) Transceiver.

Run the cables along the side of the dash at the door hinge, and place the transceiver box under your dash. For best results, consider using a zip-tie to secure the transceiver to ensure it doesn't fall from beneath the dash.

## ANTENNA PLACEMENT

The RTV-20 uses an external antenna for both GPS and GSM (cellular) signals.

When installing, it is more important to consider GPS performance over cellular (GSM) performance. GPS signal strengths are much lower than typical cellular networks supported by the RTV-20 device.

To maximize the performance of the RTV-20, placement of the antenna should have a clear view of the sky when possible. A good installation location for the antenna should typically have visibility to 14 satellites at peak. If the antenna is installed in a location which only has visibility to a maximum of 9 satellites at peak, problems may occur which will result in intermittent operation.

An installation with a maximum view of only nine satellites, may operate wonderfully most of the time, but on those occasions when six satellites drop from view due to weather or other circumstances, it would leave the antenna seeing only 3 satellites – not enough to triangulate with any accuracy. Our system does not transmit location data when less than four satellites are in view – because we know the location would not be accurate.

Make sure the device is kept free from direct exposure to the elements (sun, heat, rain, moisture, etc.)

If your installation is taking place inside a building, your unit may not receive a GPS signal or cellular signal. We highly recommend driving the vehicle around for a minimum of 5 minutes to assure optimal installation and performance of your device.

### Optimum Antenna Placement

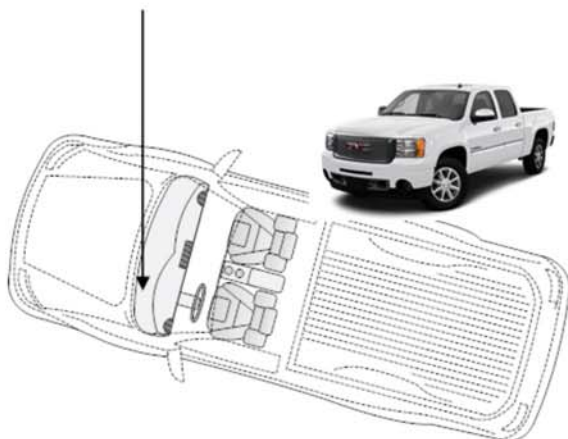

**NOTE:** GPS signals **WILL** penetrate glass, plastic, foam, fiberglass and wood. GPS signals **WILL NOT** penetrate metal. For this reason, it is important to place the antenna where it is not obstructed by metal or wiring. Placement of the antenna in a position which might be even slightly obscured by metal – including wires, wiper blades, or aluminum foil (used in some high-end vehicles on the underside of the dash to reduce the effects of the sun's heat) - may compromise antenna visibility of the GPS satellite constellation.

A good placement of antenna will yield a minimum of 9 – 14 satellites. Our device will not transmit data location when less than 4 satellites are in view because the location of device would be inaccurate.

## ANTENNA PLACEMENT AREAS

*Above and forward of instrument cluster hidden under dash.*



*Hidden inside "A" pillar.*

**WARNING:** Do not install here if antenna will obstruct, block, or interfere with airbag deployment



*Base of windshield with antenna either exposed or hidden.*



*Underneath fiberglass.*



# Installation

*Installing your new LiveViewGPS tracking system couldn't be easier - just follow these easy steps.*

## BASIC WIRING & INSTALLATION GUIDELINES

The RTV-20 requires a standard 3-wire installation to operate efficiently. Refer to "Wire Schematics" to utilize Inputs and/or Outputs including Garmin Nuvi interface functionality.

Wire Color	Signal/Description
Red Wire	12 VDC Constant
Black Wire	Ground Wire
White Wire	Ignition Wire

**The Red Wire** (Power) should be directly wired to a constant power source found under the dash. **DO NOT** wire to vehicle accessories like Radios, Cigarette Lighters, etc. but directly to the fuse box or the constant wire found in the Ignition Wiring Harness. This connection point should be fuse protected to not more than 5 Amps.

**The Black Wire** (Ground) should be securely fastened to a grounded screw under the dash.

**The White Wire** (Ignition) is the Ignition Event wire that is best installed directly to the Ignition Wire which extends the length of the steering column and is best connected where the dash and steering column meet. All makes and models of vehicles are different. For that reason, we recommend visiting [www.the12volt.com](http://www.the12volt.com) prior to installing the device to learn your particular vehicle's Constant & Ignition wires and their specific color(s). Ensure that power to the ignition wire is available **ONLY** when the vehicle ignition is turned on.

**For Inputs /Outputs** please refer to "Wire Schematics" for utilizing the input/output functions of the RTV-20 device.

Inputs: PTO usage, light bars, doors, panic, etc.

Outputs: Lock/Unlock doors, Honk Horn, Remote Start, Disable/Enable Starter.



**IMPORTANT DO NOT** cut wiring harness to shorten length of cable(s) as this will void warranty. After installing, carefully coil any excess cable length and secure with a zip-tie up under the dash. Be sure the cables are not bent or constricted in any way.

Preferred method for completing connections to the power and ignition sources is a "poke & wrap" connection. Do not solder or use T-Tap Connectors. Use standard commercial wiring practices to create a permanent installation whenever possible.

## STATUS LED'S TO INDICATE SERVICE



Status LED lights (Red & Green) are on the front of the RTV-20 device and can provide valuable information about the operation of the unit. When possible, install the unit in such a way that these lights can be seen with reasonable ease for future troubleshooting.

After installing the unit, and prior to securing under the dash area, make sure the unit has a solid Green light and a blinking Red light that goes solid for 4 seconds, then repeats the pattern. See table below for troubleshooting when one, or both, does not occur.

Condition (left LED light)	LED 1 – Red - GSM/Cellular
Modem Off	Off
Cellular On - Searching	Slow Blinking
Network Avail.	Fast Blinking
Registered but no inbound acknowledgement	Alternates from Solid to Fast Blink every 1sec.
<b>Registered and received acknowledgement</b>	<b>Blink, Blink, Solid (Pattern) that continuously repeats</b>
Condition (left LED light)	LED 2 – Green - GPS
GPS Off	Off
GPS On	Slow Blinking
GPS Time Sync.	Fast Blinking
<b>GPS Fix</b>	<b>Solid</b>

## ADVANCED WIRING SCHEMATIC

# Wiring Schematic

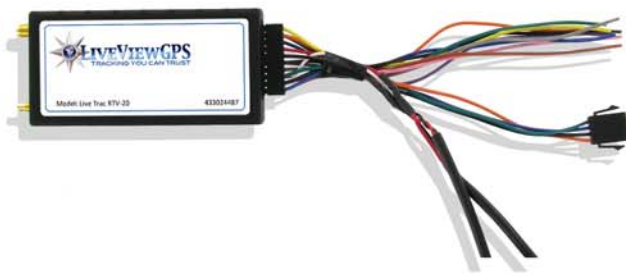
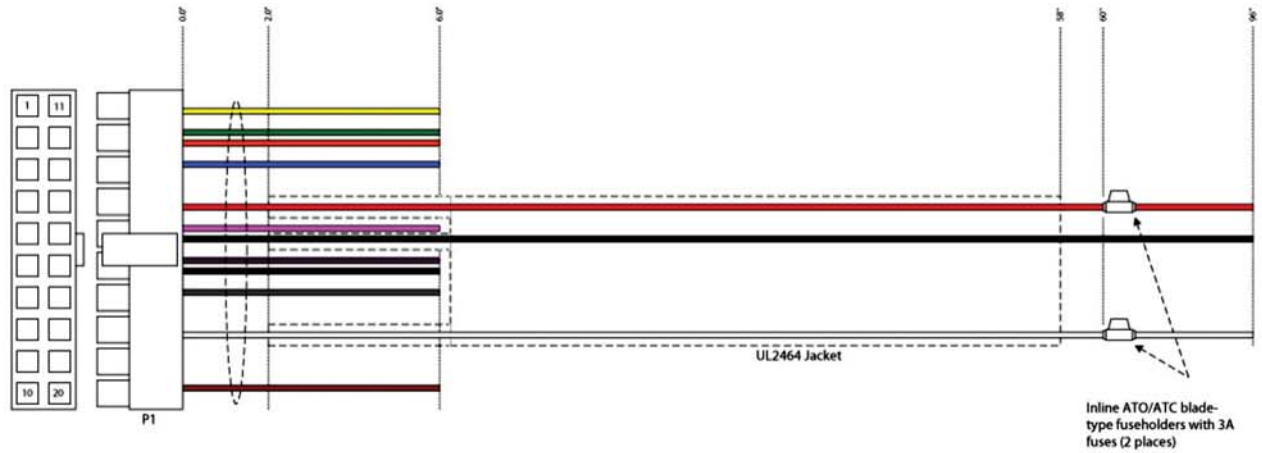

3-Wire Install with Inputs & Outputs being used	
Wire Color	Signal/Description
Black Wire	Ground Wire
Red Wire	12 VDC Constant
White Wire	Ignition Wire
Blue Wire	Input 1 - Panic/PT01+
Orange Wire	Input 2 - DT02
Violet Wire	Input 3 - DT03
Grey Wire	Input 4 - DT04
Green Wire	Output 1 - Starter Disable Relay
Brown Wire	Output 2 - Horn
Yellow Wire	Output 3 - Unlock

## STARTER DISABLE - RELAY WIRING SCHEMATIC

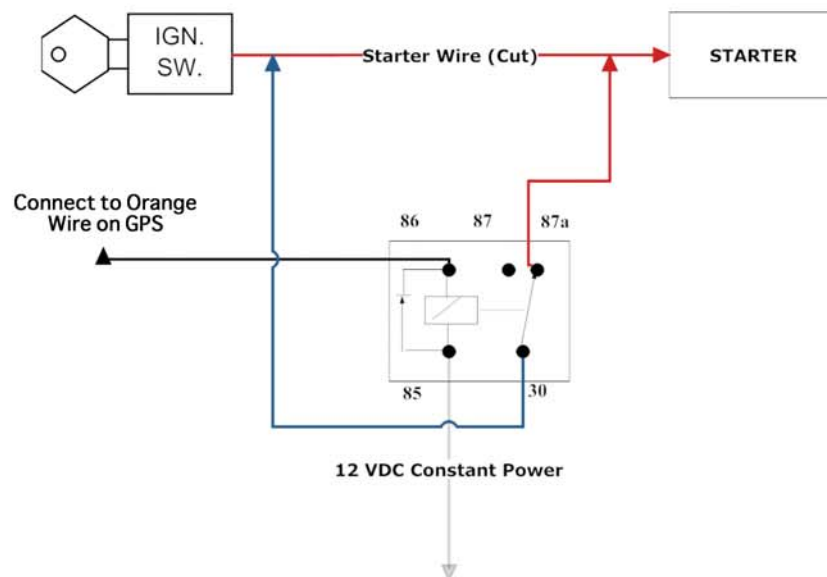

# Wiring Schematic

## DOOR UNLOCK - RELAY WIRING SCHEMATIC

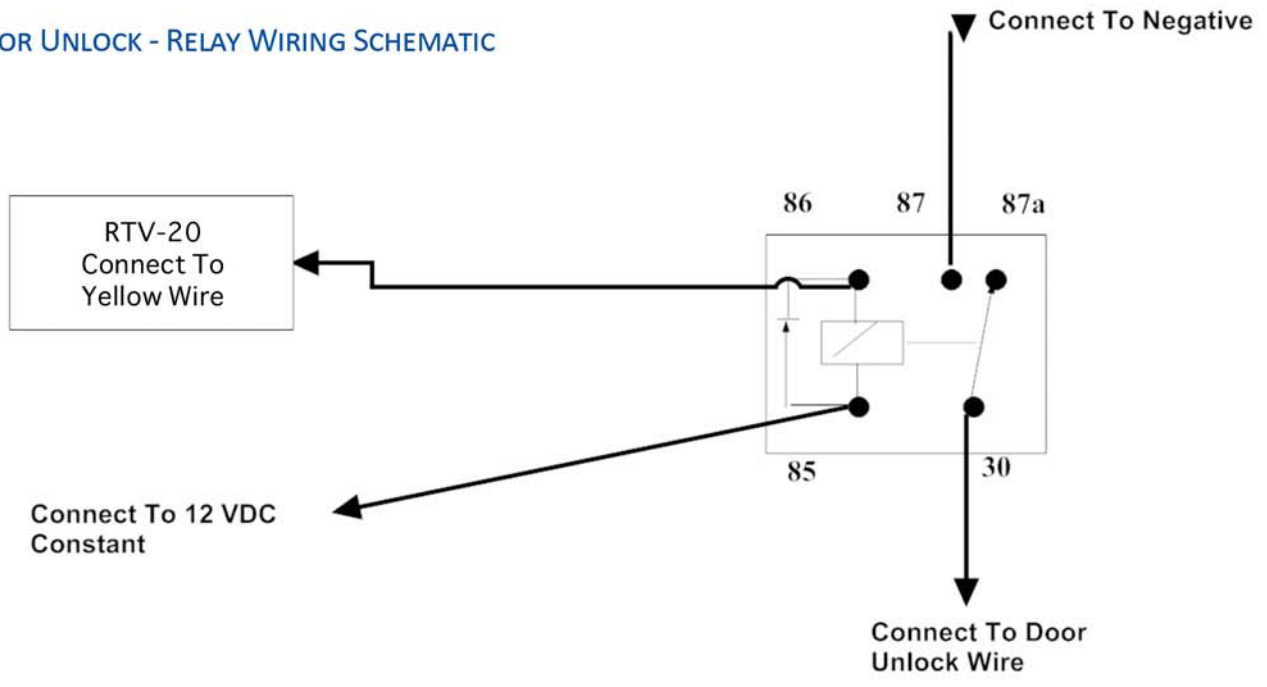

## ACCESSORY WIRING SCHEMATIC

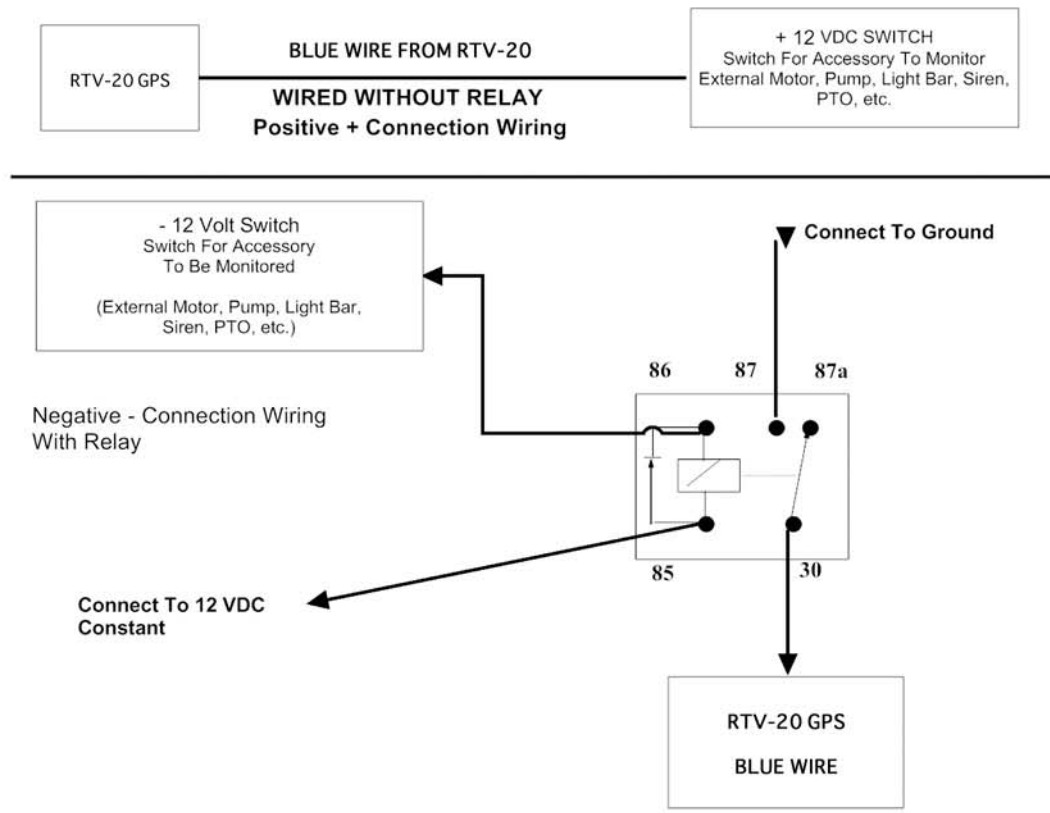

# Garmin Nuvi

**IMPORTANT** GARMIN NUVI INTEGRATION WORKS WITH THE FOLLOWING MODELS ONLY:  
GARMIN 255, 265, 465

**IMPORTANT** BEFORE CONNECTING YOUR NUVI UPDATE YOUR GARMIN DEVICE(S) to function with the Messaging and Routing feature.

Your Garmin unit comes with preloaded software that will need to be updated to function properly with our Messaging and Routing features. To download the most recent software version, visit <http://www8.garmin.com/products/webupdater/howtoinstall.jsp> and simply download WebUpdater from Garmin. Use the supplied USB cable, provided by Garmin, to install the latest software version. Connect your Garmin device to your PC and run WebUpdater.

WebUpdater is a free application that lets you update your unit software from home or office. Download it once to your desktop, and you can check for and install software updates without using your Internet web browser. Simply run WebUpdater from your computer, and it will do all of the work for you.

WebUpdater's simple interface makes it easy to upgrade your operating software. Just connect your Garmin GPS to your computer, run WebUpdater, and follow the screen prompts. After confirming that you want to perform an update, WebUpdater will download that update for you and install it on your GPS. WebUpdater always checks for its own update first before performing a unit update.

---

*To Interface with Garmin Nuvi devices ONLY use the supplied, pre-assembled Nuvi Cable.*

Wire Color	Signal/Description
Black Wire	Ground Wire
Red Wire	12 VDC Constant



# Device Specs

## RTV-20

### PHYSICAL SPECIFICATIONS

Dimensions 4" L x 2" W x .93" H  
Weight 3 Ounces  
GPS Antenna GPS/GSM Combo  
Power Connector 20 pin Molex

### ELECTRICAL SPECIFICATIONS

Operating Voltage 9 to 30 VDC  
Power Consumption  
Operating 75 mA at 12 VDC  
Deep Sleep 3mA at 12 VDC

### GSM FREQUENCY

Quad Band Class 12 GPRS Modem  
850 MHz (Class 4) – 2W  
900 MHz (Class 4) – 2W  
1800 MHz (Class 1) – 1W  
1900 MHz (Class 1) -1 W

### ENVIRONMENTAL SPECIFICATIONS

Operating -22 to 149 degrees F  
Storage -40 to 185 degrees F  
Humidity 0% to 90% relative humidity,  
non-condensing

### SHOCK & VIBRATION

SAE Test: SAE J1455 Compliant  
Mil Standard 202G and 810F Compliant  
Ground vehicle environment with  
associated shock and vibration

### EMC/EMI

SAE Test: SAE J1113 Parts 2, 12, 21 and  
41 Compliant  
FCC Part 15B Compliant  
Industry Canada Compliant  
EMC compliant for a ground vehicle  
environment

### GPS TECHNOLOGY

GPS 50 Channel Was Capable GPS Receiver  
Sensitivity -168 dBm tracking sensitivity

# Tech Support



Please contact us toll free [1-888-544-0494](tel:1-888-544-0494) or direct at [1-661-294-6805](tel:1-661-294-6805), Monday - Friday From 7 am - 5 pm PST.

Support is also available on Saturdays from 7 am - 4 pm CST. Please call: [800-761-0199](tel:800-761-0199) Option 2

You can also email: [info@liveviewgps.com](mailto:info@liveviewgps.com) for any support questions.



# Troubleshooting

By nature, any antenna placement will deteriorate signal reception even if only slightly.

If installed too far below the dash, the device may still function in areas where strong wireless data coverage is available. Despite the fact that it functions, such poor antenna placement may deteriorate signal quality from 5 bars to only 2 bars (hypothetical). In such an installation where the installation deteriorates signal quality by 3 bars, when your vehicle moves into an area where wireless data coverage only provides 4 bars of service, your device would have only 1 bar of service. Similarly, in an area where wireless coverage provides only 3 bars of service, your device would be unable to communicate due to signal deterioration based on poor antenna placement.

## Common Problems

1. The map shows my vehicle to be stopped, but the vehicle is moving.

**Remedy:** This is caused by either of two potential issues:

1) The device is not transmitting

a) Poor (or no) wireless data coverage

b) Poor antenna location resulting in deteriorated wireless data signal

c) Antenna not plugged into device

2) The GPS unit cannot see the sky (If lat=0 and lon=0, the unit will not transmit)

a) Antenna facing downward (the embossed or printed text should face the sky)

b) Poor antenna placement (GPS antenna cannot see sky through metal)

c) Antenna is placed too far below the dash to have a good view of the sky.

d) On a new install, it may take several minutes for the GPS to establish location.

**NOTE:** The unit transmits more frequently when the vehicle is moving.

a) The device transmits every 30 minutes if the vehicle is stationary.

b) The device transmits every 5 (or 10) seconds if the vehicle is moving.

2. The system shows my vehicle to be hundreds of yards from its actual location.

**Remedy:** The GPS unit does not have a good view of the sky.

a) Under normal circumstances (with a good view of the sky) our devices are accurate to within 10-12 inches. There are 26 satellites in the GPS constellation. The more satellites the device can see, the more accurate the location.

b) When vehicles are parked facing tall buildings (or in indoor garages or under metal awnings) large portions of the sky are often obscured.

c) Antenna placement is critical to ensure reliable and accurate operation.

3. When the device came on this morning, it showed the location from (another time).

**Remedy:** The brown wire is not correctly connected to the accessory 12v (ignition) power source. When the device shuts down, it stores its last known location in a buffer. If the brown wire is not connected, the device cannot perform a graceful shutdown and thus cannot store its last known location properly.

4. I log in, and all I get is a map of the US. My vehicle doesn't show.

**Remedy:** In almost every case, this is because it's a newly installed device and the unit hasn't yet transmitted its first packet of data (and thus cannot appear on the map because we don't yet know its location). It generally takes approximately 5 minutes after a new device has been powered up to begin transmitting.

This process can be hastened by driving the vehicle. Under normal circumstances, the device transmits every 5-10 seconds (depending on your wireless plan) when the vehicle is moving, but only once every 15-30 minutes if the vehicle is stationary. For this reason, it could take up to 30 minutes to make its first transmission if the vehicle remains stationary.

# Legal Notice

© 2005-2011 LiveViewGPS, Inc.  
All Rights Reserved.

This product or document is protected by copyright and distributed under the terms of a license agreement, restricting its use, copying, distribution and decompilation ("License Agreement"). No part of this document may be distributed without written consent from LiveViewGPS, Inc.

The product described in this document may be protected by one or more U.S. patents, foreign patents, or pending applications.

U.S. Patent Number 5,963,956 and 6,647,269. U.S. Patents Pending.

## RESTRICTED RIGHTS/SPECIAL LICENSE RIGHTS

The documentation is provided with RESTRICTED RIGHTS. Use, duplication, or disclosure by the Government is subject to restrictions as set forth in the License Agreement and in subparagraphs (c)(1)(ii) of the Rights in Technical Data and Computer Software clause at DFARS 252.227-7013 or subparagraphs (c)(1) and (2) of the Commercial Computer Software—Restricted Rights at 48 CFR 52.227-19, or their equivalent, as applicable.

## WARRANTY COVERAGE

LiveViewGPS, Inc. (LVGPSI)'s warranty obligations for this RTV-20 series tracking unit are limited to the terms set forth below:

LVGPSI warrants the LVGPSI RTV-20 series tracking unit against defects in materials and workmanship for a period of one (1) year from the date of original purchase ("Warranty Period").

Specifically, the date the equipment is shipped to the customer.

If a defect arises and a valid claim is received by LVGPSI within the Warranty Period, at its option, LVGPSI will (1) repair the product at no charge, using new or refurbished replacement parts, (2) exchange the product with a product that is new or which has been manufactured from new or serviceable used parts and is at least functionally equivalent to the original product, or (3) refund the purchase price of the product.

LVGPSI warrants replacement products or parts provided under this warranty against defects in materials and workmanship from the date of the replacement or repair for ninety (90) days OR for the remaining portion of the original product's warranty, whichever provides longer coverage for you. When a product or part is exchanged, any replacement item becomes your property and the replaced item becomes LVGPSI's property. When a refund is given, your product becomes LVGPSI's property.

This Limited Warranty does not apply to any non-LVGPSI hardware product or any software. LVGPSI is not liable for any damage to or loss of any programs, data, or other information stored on any media contained within the vehicle tracking or navigation systems.

This warranty does not apply: (a) to damage caused by accident, abuse, misuse, misapplication, or non-LVGPSI products; (b) to damage caused by electrical connection not conforming to instructions; (c) to a product or a part that has been modified without the written permission of LVGPSI; (d) if any LVGPSI serial number has been removed or defaced; (e) in the event of interruption or discontinuation of GPS satellite signal; or (f) in the event of interruption or discontinuation of the wireless coverage.

To the maximum extent permitted by law, this warranty and the remedies set forth above are exclusive and in lieu of all other warranties, remedies and conditions, whether oral or written, express or implied. LVGPSI specifically disclaims any and all implied warranties, including, without limitation, warranties of merchantability and fitness for a particular purpose. If LVGPSI cannot lawfully disclaim or exclude implied warranties under applicable law, then to the extent possible any claims under such implied warranties shall expire on expiration of the warranty period. No LVGPSI reseller, agent, or employee is authorized to make any modification, extension, or addition to this warranty.

## SPECIFIC LIMITATION OF LIABILITY

To the maximum extent permitted by law, LVGPSI assumes no liability for direct, special, incidental or consequential damages of any kind under any circumstance resulting from the use of or inability to use LVGPSI products. Use of LVGPSI products constitutes your agreement to and acceptance of this limitation of LVGPSI liability.

As a knowledgeable and informed person, the user specifically acknowledges LVGPSI is not responsible for direct, special, incidental or consequential damages resulting from any breach of warranty or condition, or under any other legal theory, including any costs of recovering or reproducing any program or data stored in or used with the LVGPSI product, and any failure to maintain restricted airtime usage or failure to maintain the confidentiality of data stored on the product. LVGPSI specifically does not represent that it will be able to repair any product under this warranty or make a product exchange without risk to or loss of programs or data.

## OBTAINING WARRANTY SERVICE

Please email [info@liveviewgps.com](mailto:info@liveviewgps.com) with your LVGPSI model and serial number, and describe the anomaly in detail. LVGPSI will respond to your email with proper user diagnosis and repair or provide you with an authorization number and instruction for shipment for authorized repair. Use care and original shipping container to prevent shipping damage. No repair work will be done and your tracking unit will not be returned if an authorization number is not obtained in advance.

*Thank You For Your Purchase! We Strive For Complete Customer Satisfaction, & Superior Customer Service. Please Do Not Hesitate To Contact Us.*



*Toll Free: 1-888-544-0494*

*Fax: 1-800-557-4314*

*Direct: 1-661-294-6805*

LiveView GPS, Inc. | 29021 Avenue Sherman, Ste 103 | Valencia, CA 91355